

APPENDIX OF ZONING
ILLUSTRATIONS

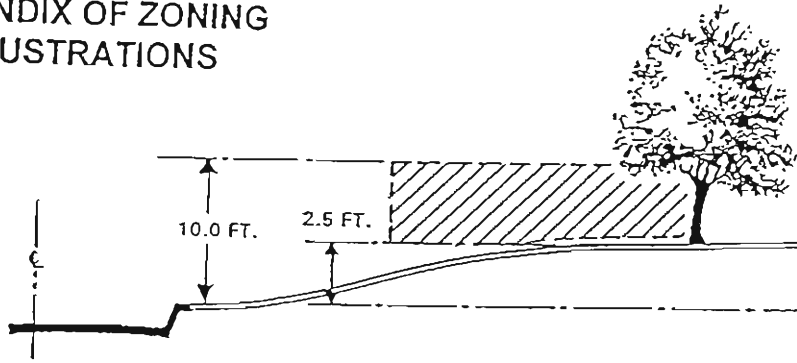

ILLUSTRATION NO. 1 VISION CLEARANCE

VISION CLEARANCE TRIANGLE
(PLAN VIEW)

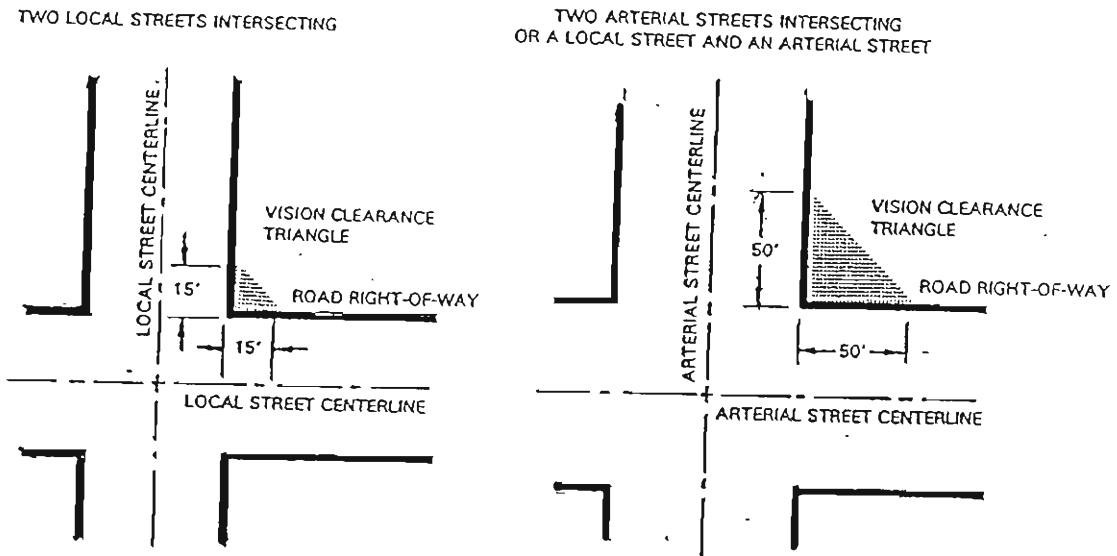

ILLUSTRATION NO. 2 VISION CLEARANCE (PLAN VIEW)

ILLUSTRATION OF A TYPICAL
PARKING LOT LANDSCAPE ISLAND

TYPICAL PARKING LOT

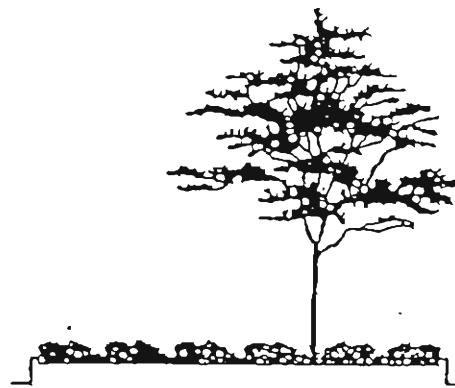
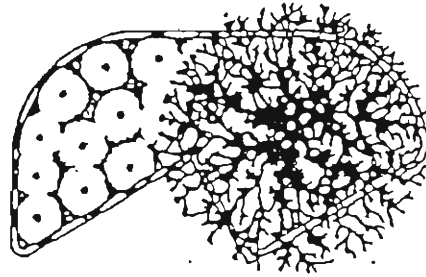
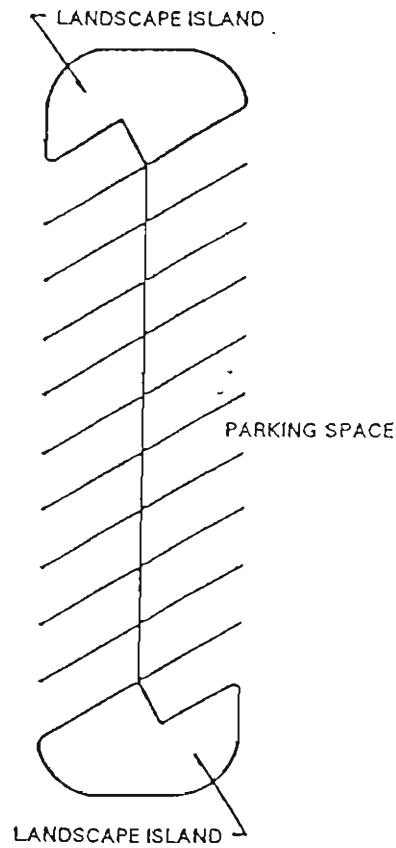

ILLUSTRATION NO. 3 A TYPICAL PARK LANDSCAPE ISLAND

ILLUSTRATION OF TYPICAL
LANDSCAPING FOR
PARKING ADJACENT TO A BUILDING

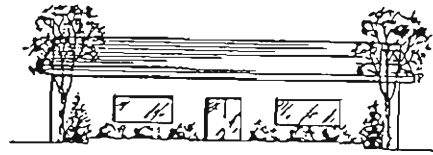
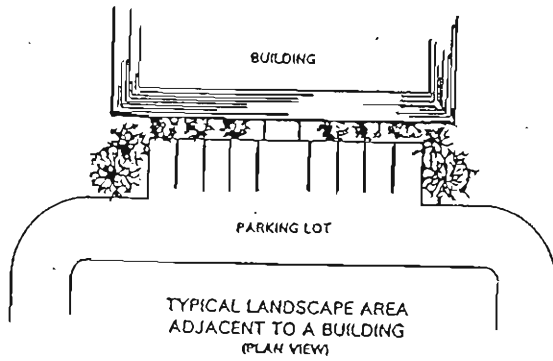

ILLUSTRATION NO. 4 LANDSCAPING FOR PARKING ADJACENT TO A BUILDING

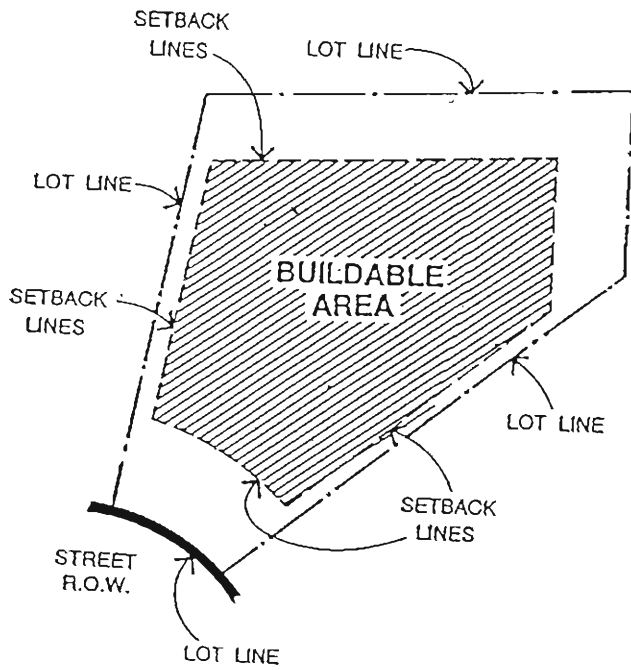

ILLUSTRATION NO. 5 BUILDABLE AREA

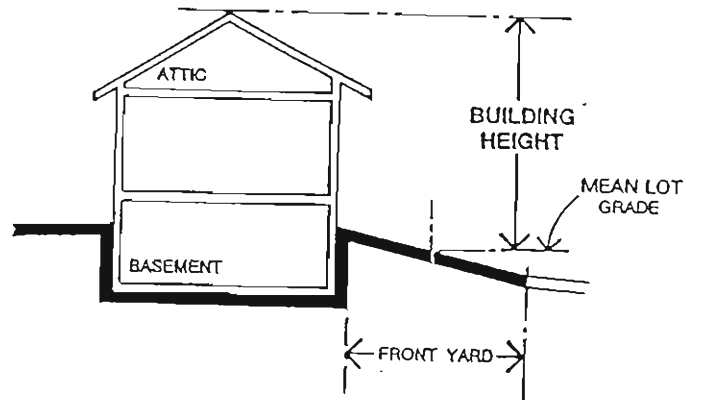

ILLUSTRATION NO. 6 BUILDING HEIGHT

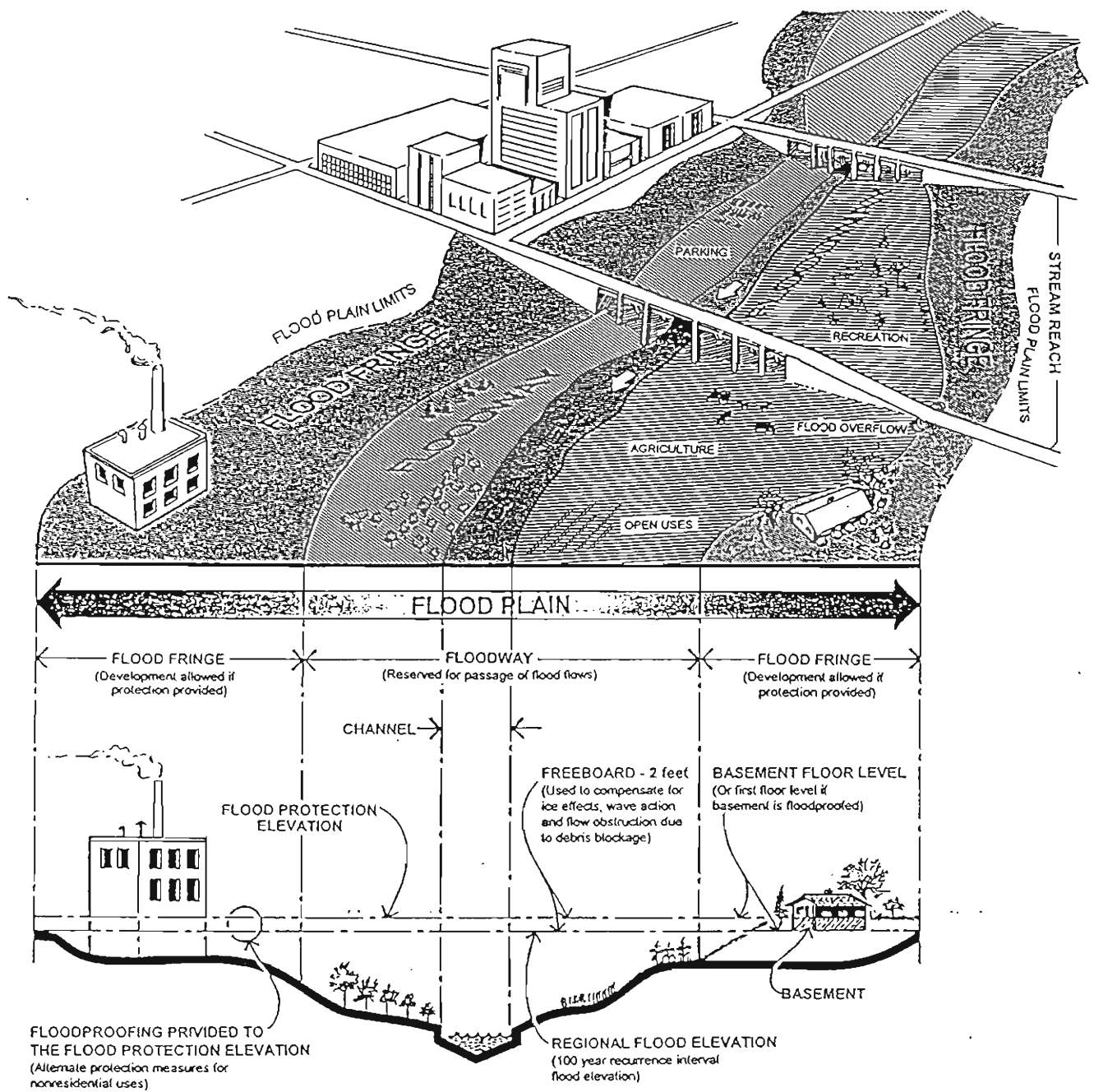

ILLUSTRATION NO. 7 FLOOD PLAIN

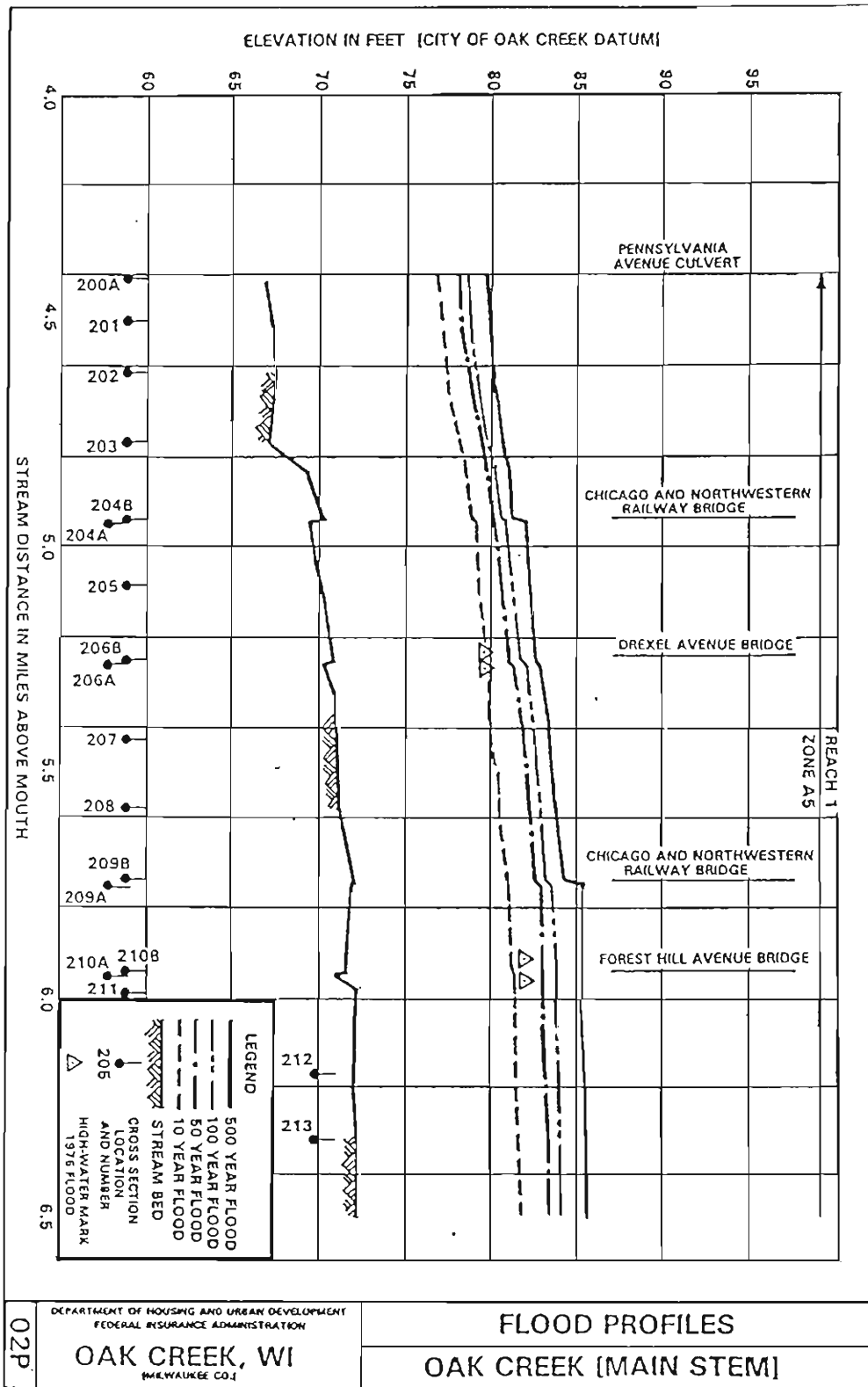

ILLUSTRATION NO. 8 FLOOD PROFILES

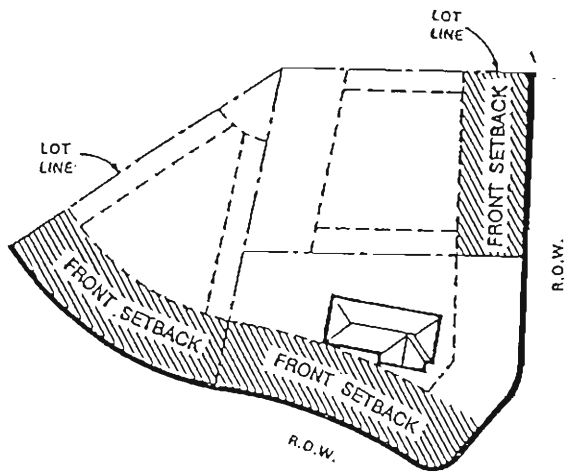

ILLUSTRATION NO. 9 FRONT SETBACK

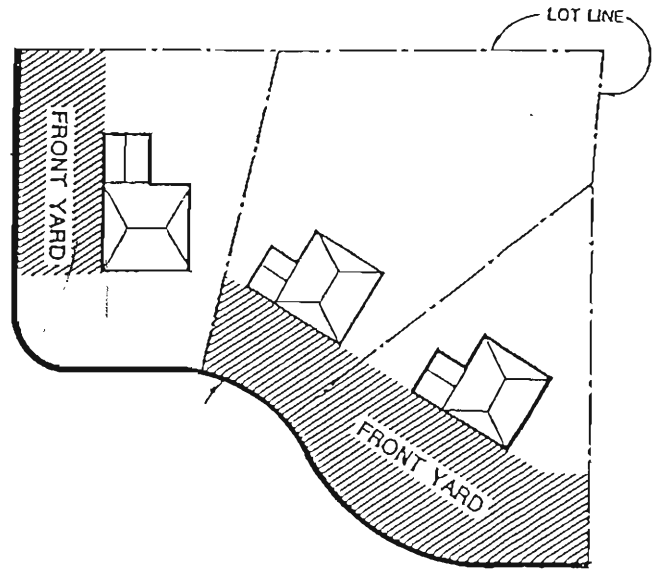

ILLUSTRATION NO. 10 FRONT YARD

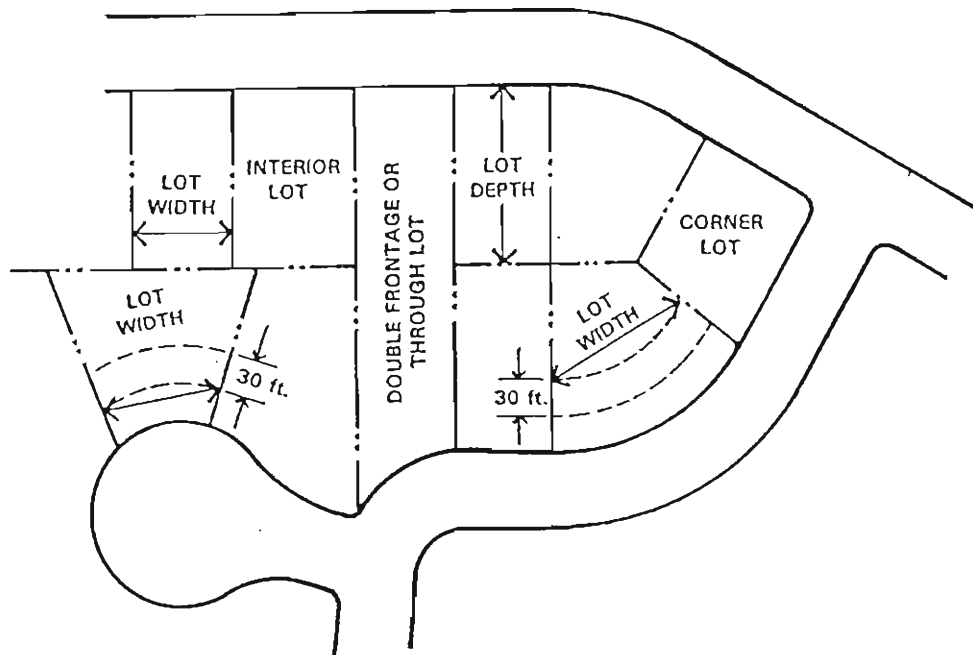

ILLUSTRATION NO. 11 DOUBLE FRONTAGE OR THROUGH LOT

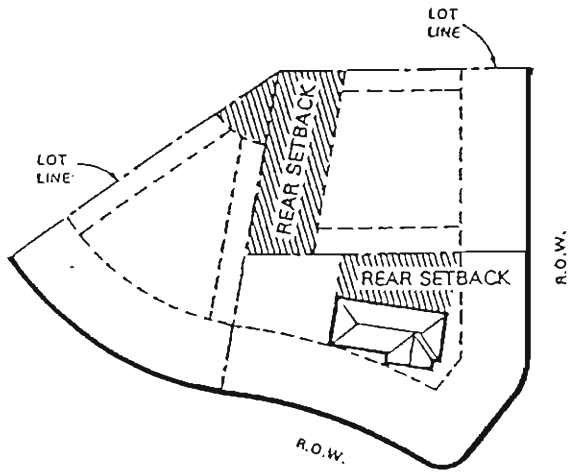

ILLUSTRATION NO. 12 REAR SETBACK

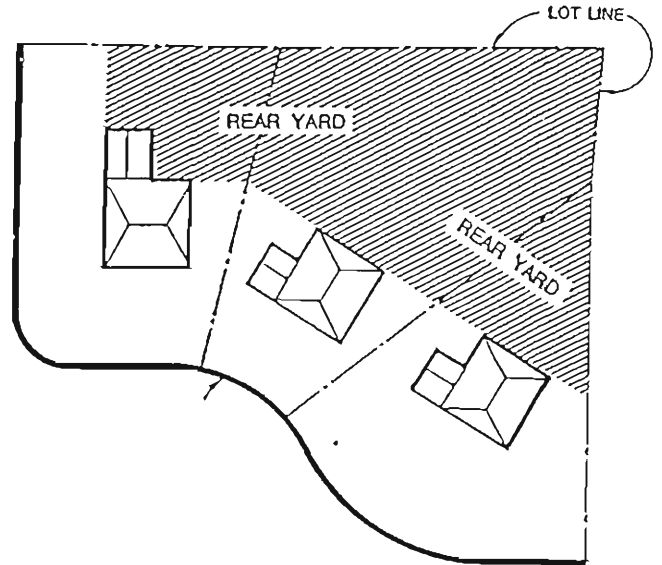

ILLUSTRATION NO. 13 REAR YARD

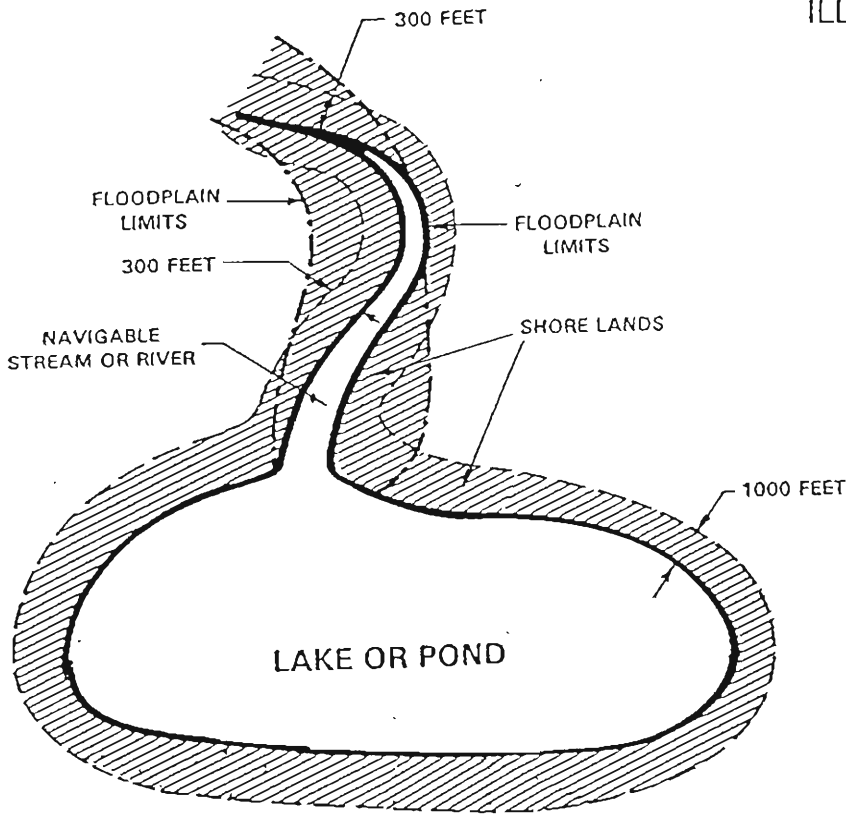

ILLUSTRATION NO. 14 SHORELAND AREAS

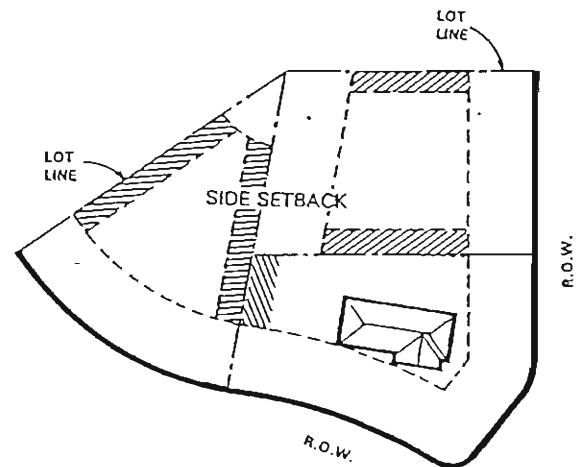

ILLUSTRATION NO. 15 SIDE SETBACK

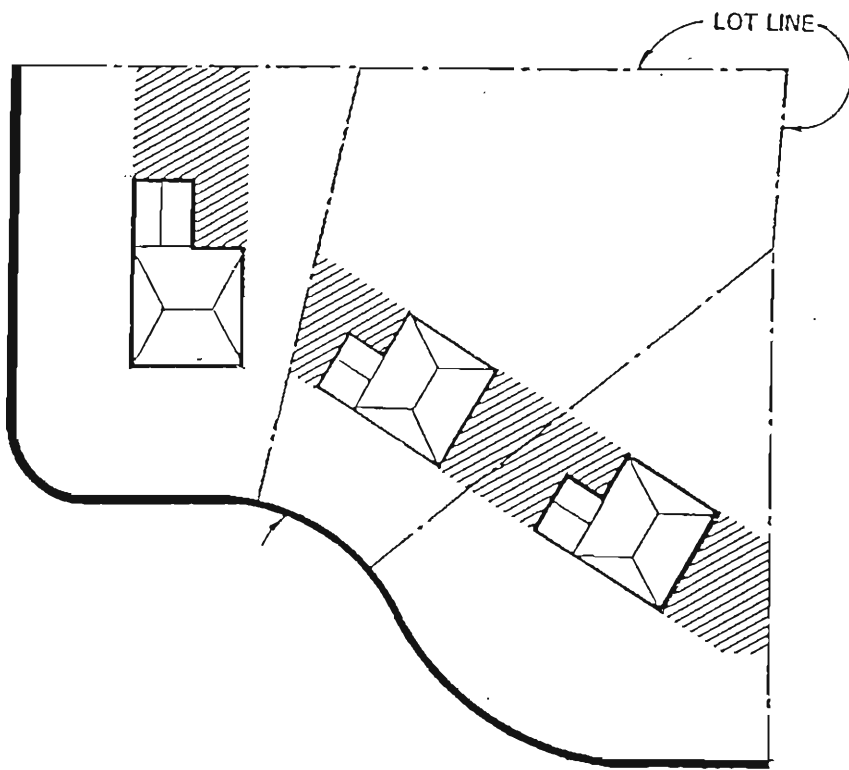
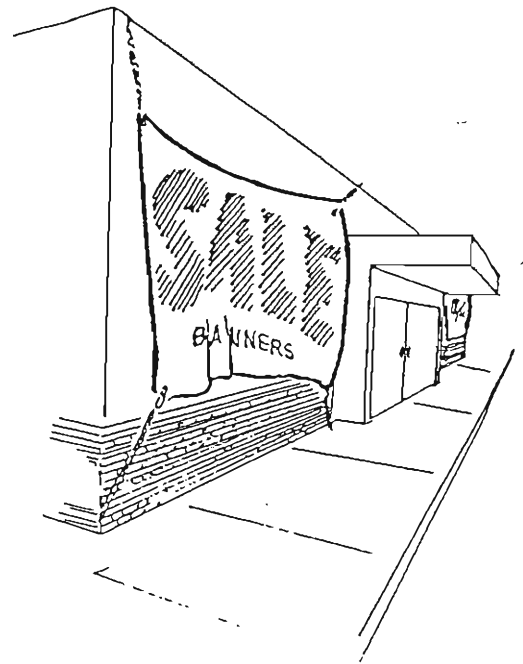

ILLUSTRATION NO. 16 SIDE YARD



AWNING SIGNS
 MAXIMUM SIGN AREA = 2 SQ. FT.

ILLUSTRATION NO. 17 AWNING SIGNS



BANNERS
 MAXIMUM SIGN AREA = 32 SQ. FT. PER
 SIDE OR 64 SQ. FT. TOTAL

ILLUSTRATION NO. 18 BANNERS

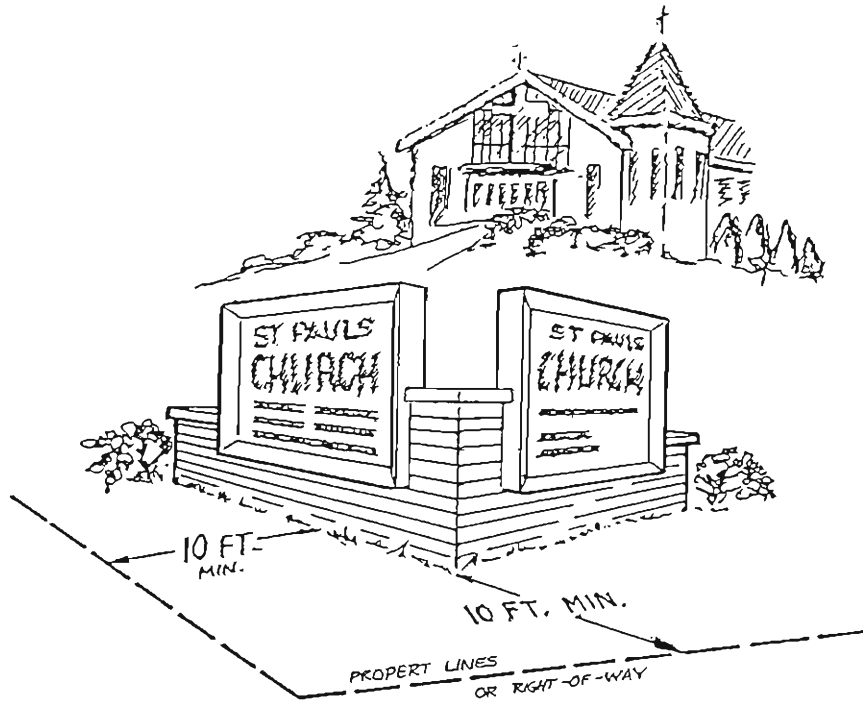

BULLETIN BOARD SIGNS
 MAXIMUM SIGN AREA = 48 SQ. FT./SIDE

ILLUSTRATION NO. 19 BULLETIN BOARD SIGNS

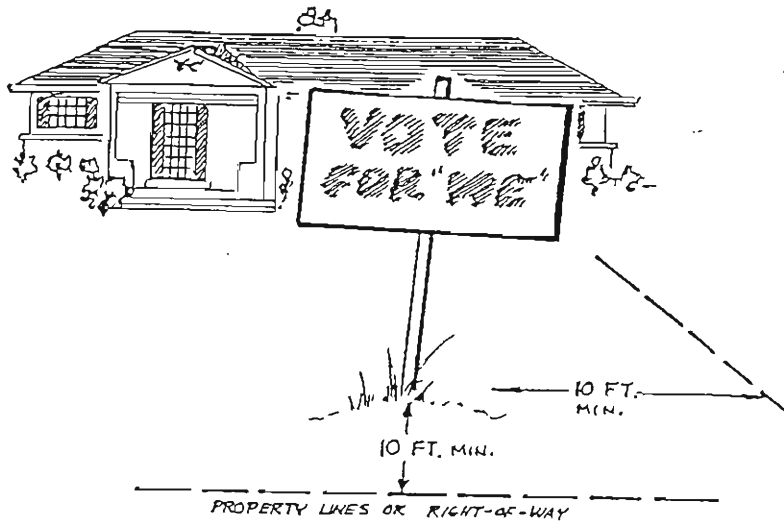

ELECTION CAMPAIGN SIGNS
 MAXIMUM SIGN AREA = 32 SQ. FT.

ILLUSTRATION NO. 20 ELECTION CAMPAIGN SIGNS

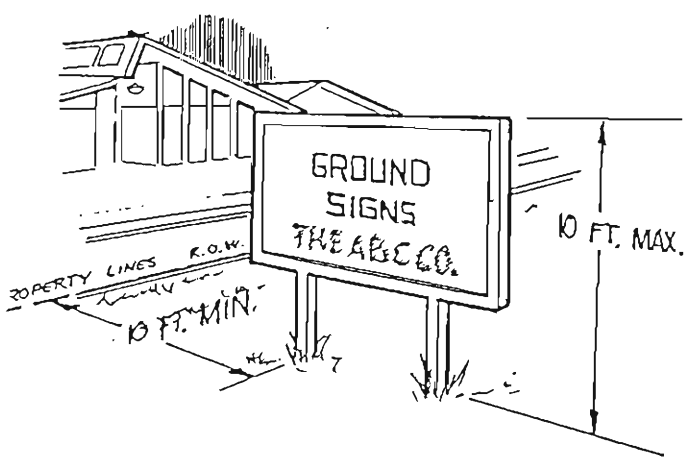

GROUND SIGNS
 MAXIMUM SIGN AREA = 100 SQ. FT. PER SIDE
 OR 200 SQ. FT. TOTAL

ILLUSTRATION NO. 21 GROUND SIGNS

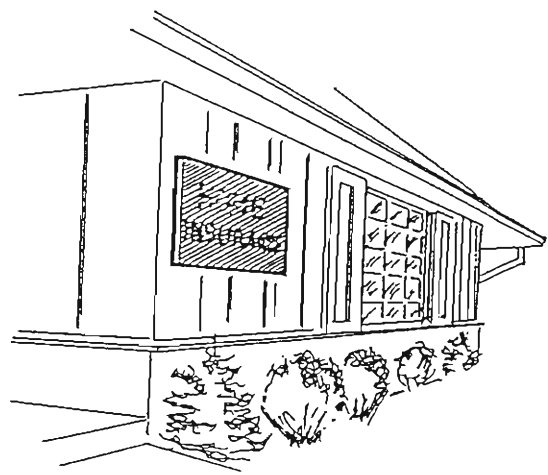

**HOME OCCUPATION & PROFESSIONAL
 HOME OFFICE SIGNS**
 MAXIMUM SIGN AREA = 2 SQ. FT.

ILLUSTRATION NO. 22 HOME OCCUPATION & PROFESSIONAL HOME OFFICE SIGNS

ILLUSTRATION NO. 23 MOBILE (PORTABLE) SIGNS

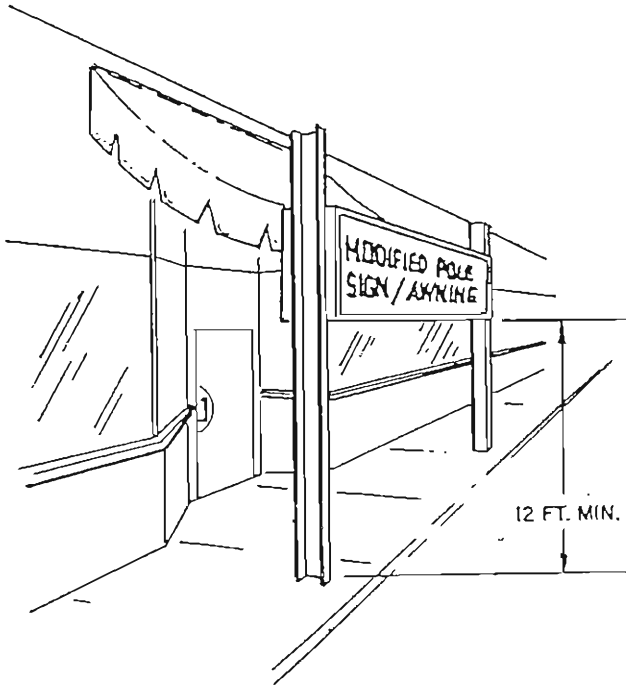

MODIFIED POLE/AWNING SIGNS
 MAXIMUM SIGN AREA = 2 SQ. FT.

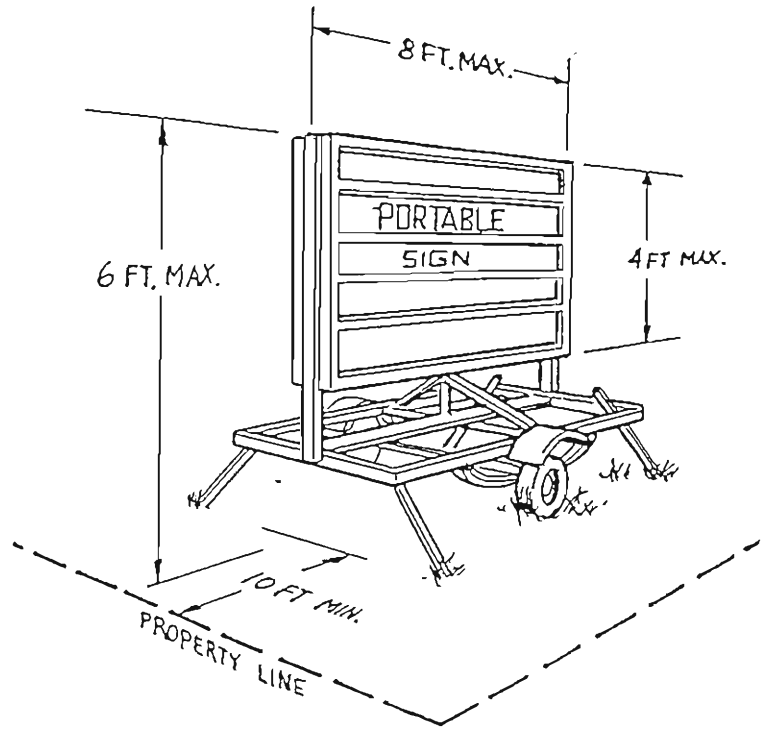

MOBILE (PORTABLE) SIGNS
 MAXIMUM SIGN AREA = 32 SQ. FT. PER SIDE
 OR 64 SQ. FT. TOTAL

ILLUSTRATION NO. 24 MODIFIED POLE/AWNING SIGNS

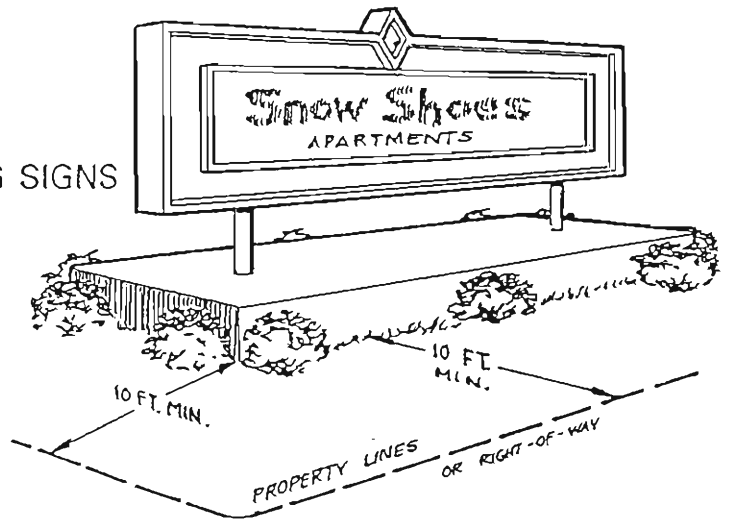

MULTIFAMILY DEVELOPMENT SIGNS
 MAXIMUM SIGN AREA = 48 SQ. FT./SIDE

(ACTUAL SIZE DETERMINED BY THE PLAN COMMISSION)

ILLUSTRATION NO. 25 MULTIFAMILY DEVELOPMENT SIGNS

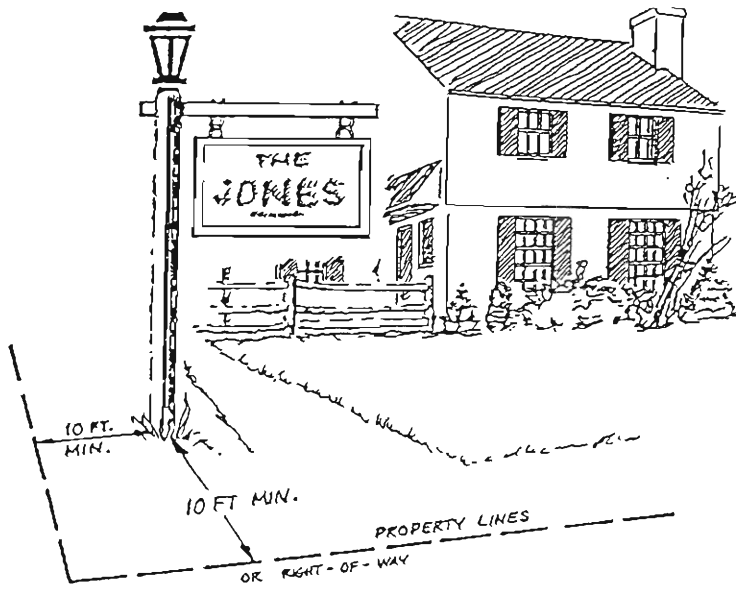

NAME SIGNS
 MAXIMUM SIGN AREA = 2 SQ. FT.

ILLUSTRATION NO. 26 NAME SIGNS

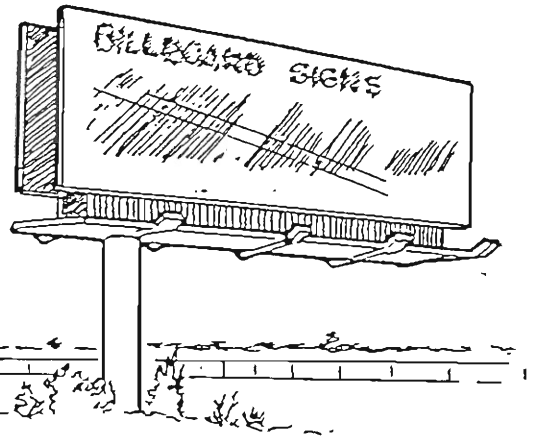

OFF-PREMISE ADVERTISING SIGNS

ILLUSTRATION NO. 27 OFF-PREMISE ADVERTISING SIGNS

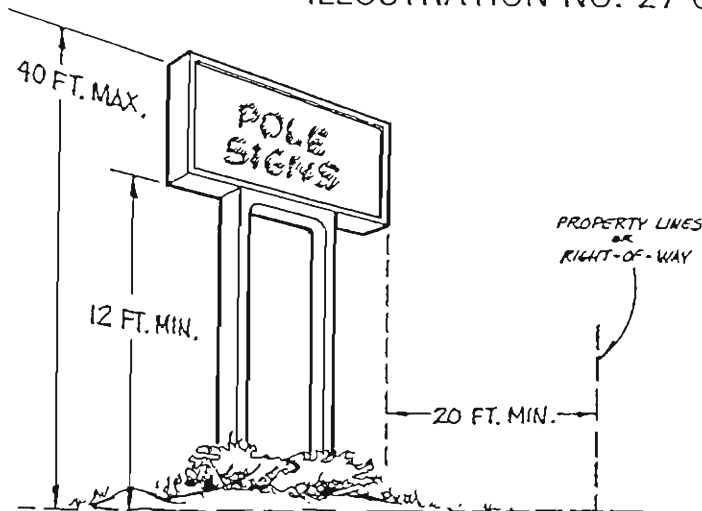

POLE SIGNS

MAXIMUM SIGN AREA = 400 SQ. FT./SIDE
 800 SQ. FT. TOTAL

ILLUSTRATION NO. 28 POLE SIGNS

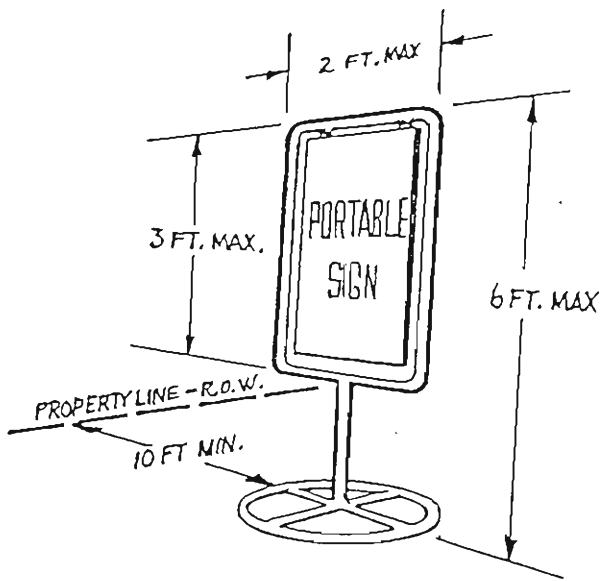

PORTABLE SIGNS
 MAXIMUM SIGN AREA = 32 SQ. FT./SIDE OR 64 SQ. FT. TOTAL

ILLUSTRATION NO. 29 PORTABLE SIGNS

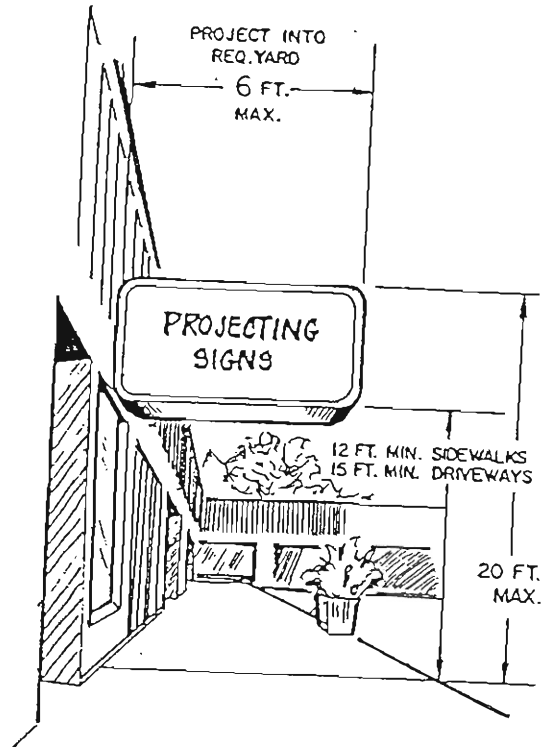

PROJECTING SIGNS
 MAXIMUM SIGN AREA = 48 SQ. FT./SIDE OR 96 SQ. FT. TOTAL

ILLUSTRATION NO. 30 PROJECTING SIGNS

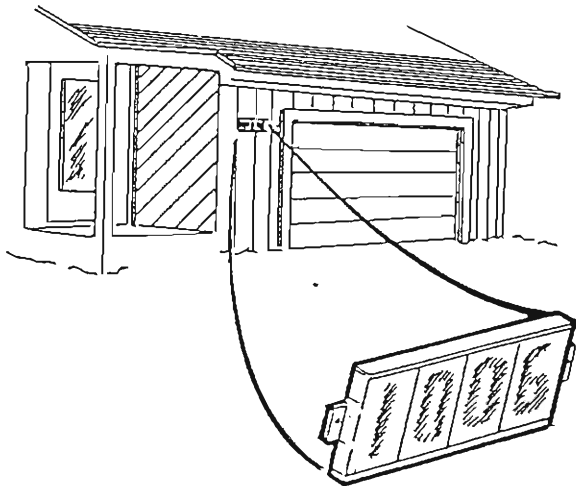

PROPERTY ADDRESS SIGNS

ILLUSTRATION NO. 31 PROPERTY ADDRESS SIGNS

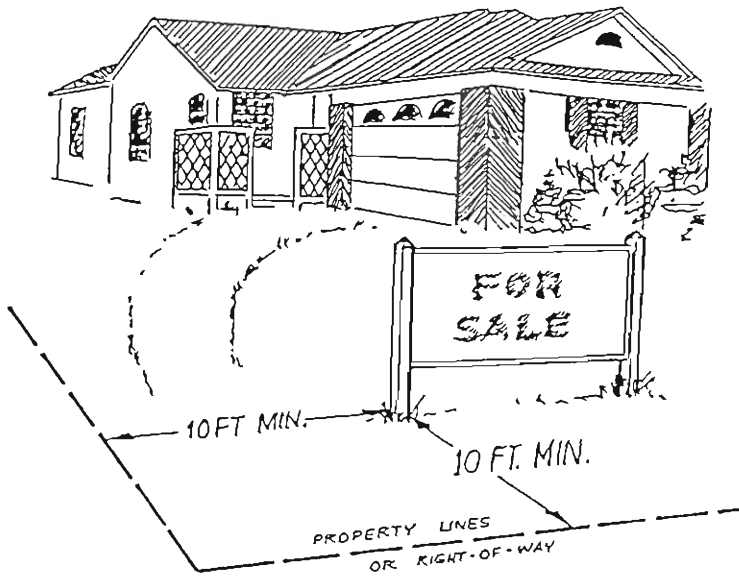

REAL ESTATE SIGNS
 RESIDENTIAL MAXIMUM SIGN AREA = 8 SQ. FT
 ALL OTHER DISTRICTS = 32 SQ. FT.

ILLUSTRATION NO. 32 REAL ESTATE SIGNS

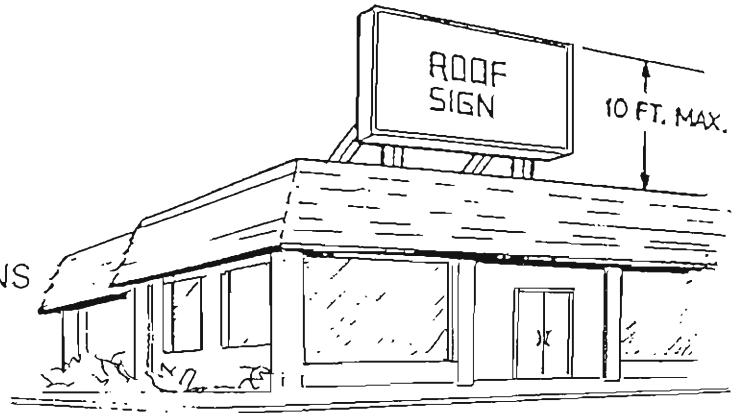

ROOF SIGNS
 MAXIMUM SIGN AREA = 400 SQ. FT. PER SIDE
 OR 800 SQ. FT. TOTAL

ILLUSTRATION NO. 33 ROOF SIGNS

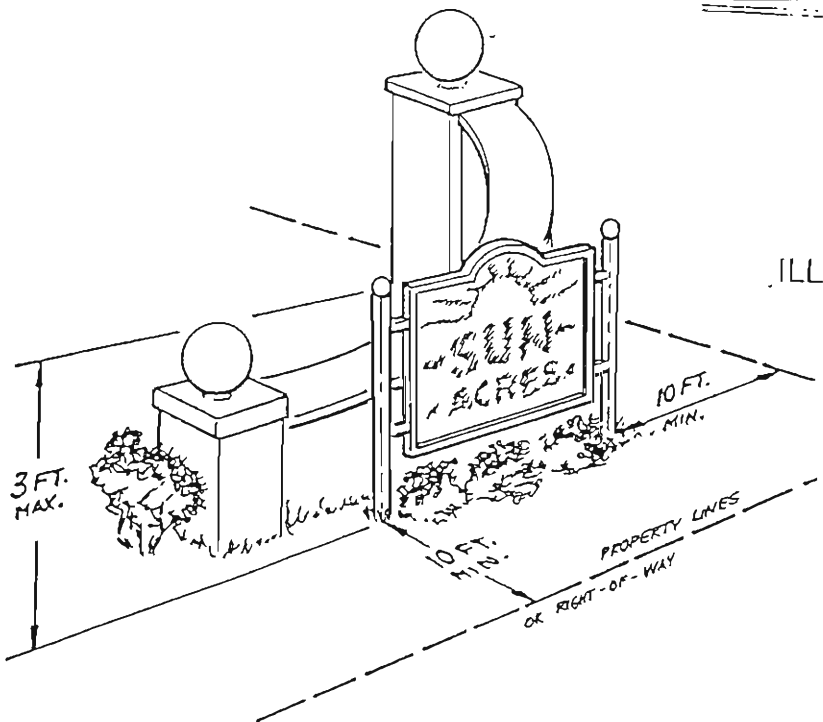

SINGLE AND TWO-FAMILY RESIDENTIAL DEVELOPMENT SIGNS
 MAXIMUM SIGN AREA = 10 SQ. FT./SIDE
 20 SQ. FT. TOTAL WITH ACTUAL SIZE DETERMINED
 BY THE PLAN COMMISSION

ILLUSTRATION NO. 34 RESIDENTIAL DEVELOPMENT SIGNS (PERMANENT)

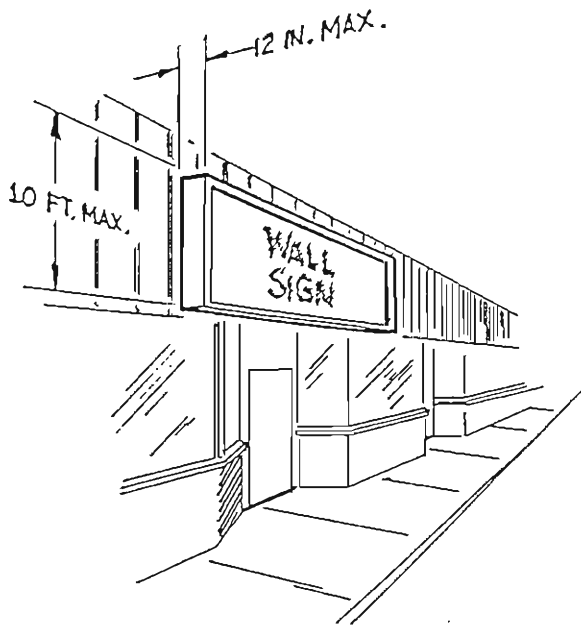

WALL SIGNS

MAXIMUM SIGN AREA = 20% OF THE WALL AREA
 BUT SHALL NOT EXCEED 600 SQ. FT.

ILLUSTRATION NO. 35 WALL SIGNS

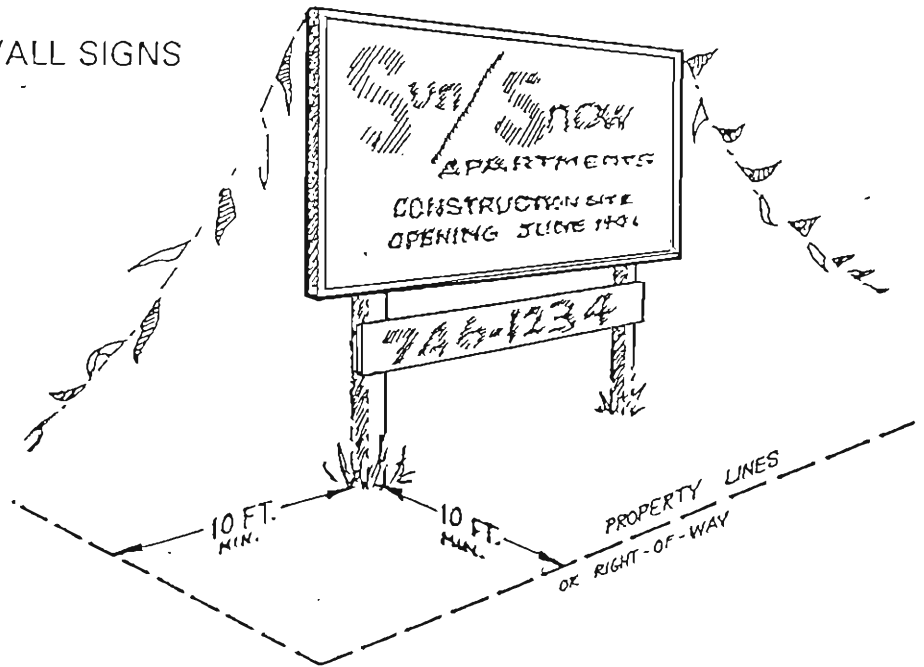

TEMPORARY DEVELOPMENT SIGNS

MAXIMUM SIGN AREA = 48 SQ. FT. PLAN COMMISSION
 TO DETERMINE LENGTH OF TIME, NOT TO EXCEED 2 YEARS

ILLUSTRATION NO. 36 TEMPORARY DEVELOPMENT SIGNS

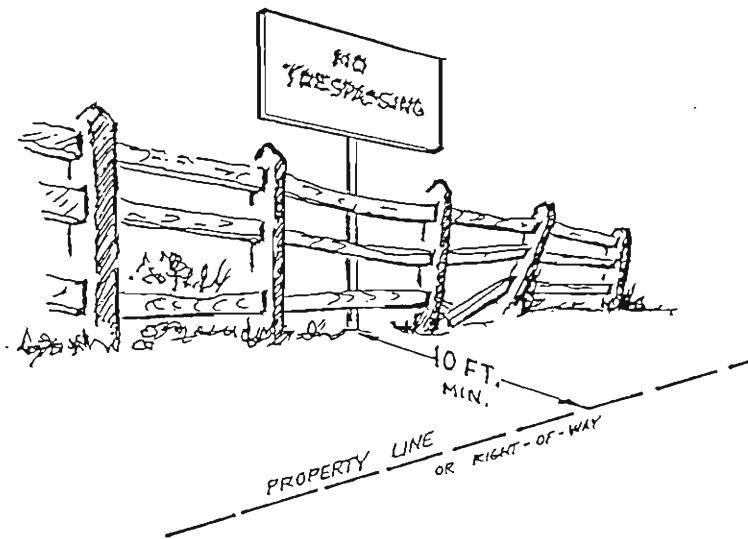

WARNING SIGNS
MAXIMUM SIGN AREA = 2 SQ. FT.

ILLUSTRATION NO. 37 WARNING SIGNS

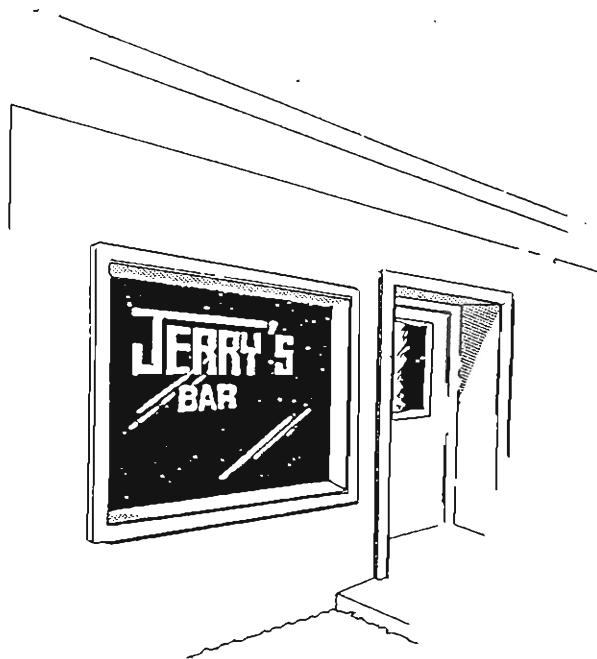

ILLUSTRATION NO. 38 WINDOW SIGNS

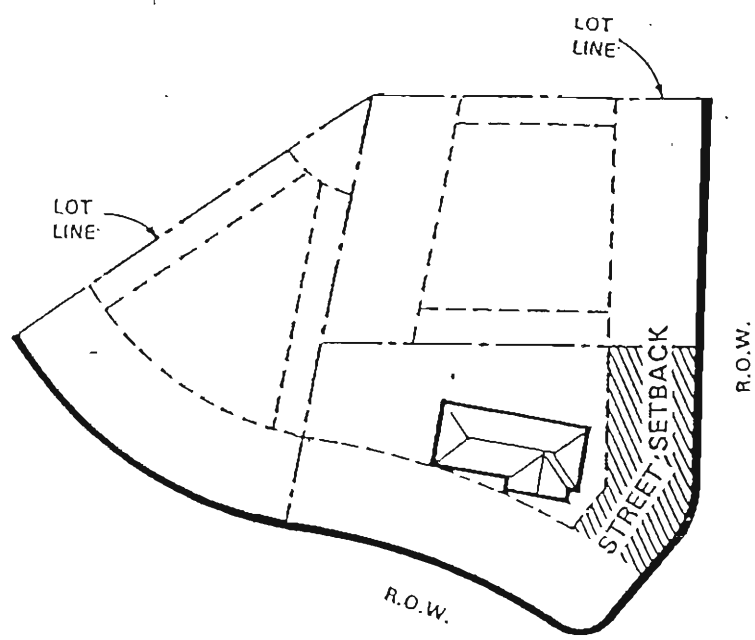

ILLUSTRATION NO. 39 STREET SETBACK

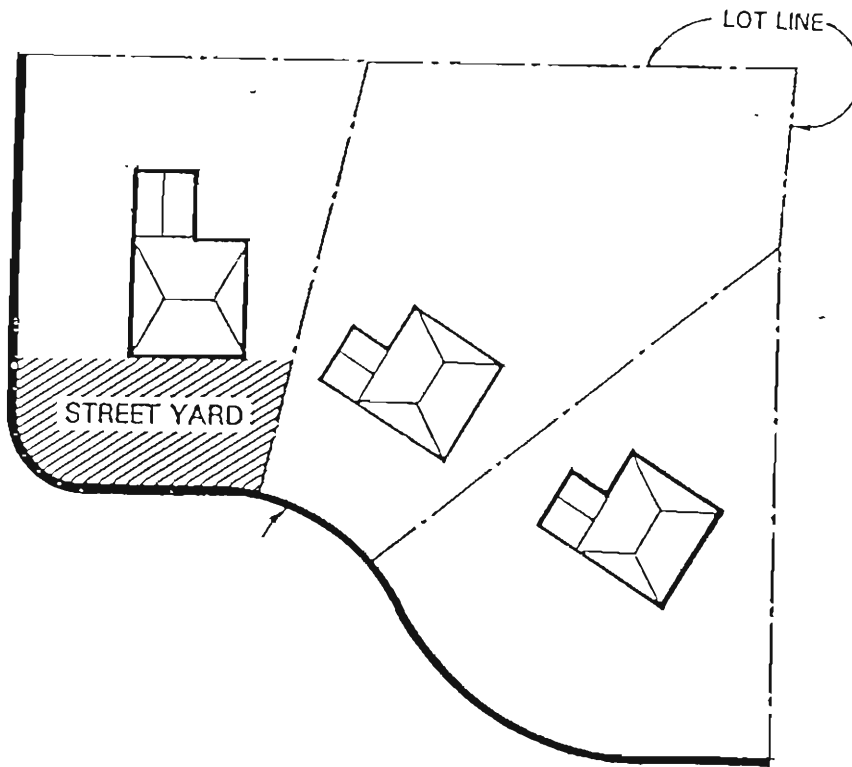

ILLUSTRATION NO. 40 STREET YARD